

JUNIORFLUX



Special features:

- ▶ Motor and pump tightly connected
- ▶ Two pump types available - with mechanical seal or sealless
- ▶ With mains connection
- ▶ Internal ventilated commutator motor
- ▶ Motor double insulated - protection class II
- ▶ Two step speed adjustment
- ▶ With overload cut-out switch
- ▶ 230 Volt version VDE-GS approved
- ▶ Ergonomic design handle - one-handed operation
- ▶ Holding hook for medium hose

Commutator motor FEM 3070

Motor type	Storage of motor	Speed control	Allowed ambient temperature in operation	Allowed ambient temperature on storage	Max. viscosity [cPs]	Protection class	Weight	Protection class
internally ventilated commutator motor	ball-bearing	2-steps	-4 - 104°F (-20 - 40°C)	-4 - 140°F (-20 - 60°C)	250	IP24	3.31 lbs (1.5 kg)	II

Nominal voltage [V]	Power frequency [Hz]	Rated power [W]	Type of plug according to norm:	Cable length [m]
240	50	230	Europe: CEE 7/XVII	16 ft (5 m)
230	50-60	230	Europe: CEE 7/XVII Switzerland: Typ 11	16 ft (5 m)
120	60	230	North America: NEMA 1-15P	16 ft (5 m)
110	50-60	230	Europe: CEE 7/XVII	16 ft (5 m)
100	50-60	230	Japan: JISC 8308, 8358 7A	16 ft (5 m)

Pumpe F 310/F 314

Type	F 310 PP- 25/19	F 310 PP- 32/25	F 314 PP-25/19	F 314 PP-32/25	F 314 PVDF-25/19	F 314 S-28/25
Outer tube material	polypropylene				polyvinylidene fluoride	stainless steel
Type of seal	with mechanical seal			sealless		
Immersion length	12"/20"/27"/39" (300/500/700/ 1000 mm)		20", 27", 39" (500/700/1000 mm)			
Outer Ø [mm]	25	32	25	32	25	28
Connection thread	G1 A*					G ¾ A
Materials in contact with the medium	PP, ETFE, Oxidkeramik/ PTFE/carbon, FKM, Hastelloy C		PP, ETFE, PTFE/ carbon, Hastelloy C		PVDF, ETFE, PTFE/ carbon, Hastelloy C	S (316 Ti), ETFE, PTFE/ carbon
Viscosity max. [cPs]	250					
Temperature of medium max.	113°F (45°C)				140°F (60°C)	
Weight including motor at a length of 300/500/700/1000 mm	3.5/4.0/4.4/4.6 lbs (1.6/1.8/2.0/2.1 kg)	- /4.0/4.4/4.6 lbs (- /1.8/2.0/2.1 kg)	- /4.0/4.4/4.6 lbs (- /1.8/2.0/2.1 kg)	- /4.0/4.4/4.6 lbs (- /1.8/2.0/2.1 kg)	- /4.4/4.6/4.8/5.3 lbs (- /2.0/2.2/2.4 kg)	- /6.2/6.6/7.1 lbs (- /2.8/3.0/3.2 kg)

*Hose connections 1/2" (DN13) and 3/4" (DN19) included

Performance data

JUNIORFLUX

Performance data

Speed	Delivery rate Q max.* at:		Delivery head H max.** at:	
	step 1	step 2	step 1	step 2
F 310 PP-25/19	4.5 GPM (17 LPM)	7.1 GPM (27 LPM)	7.2 ft (2.2 m)	16.4 ft (5 m)
F 310 PP-32/25	7.9 GPM (30 LPM)	12.6 GPM (48 LPM)	9.8 ft (3 m)	22.6 ft (6.9 m)
F 314 PP-25/19 F 314 PVDF-25/19	7.1 GPM (27 LPM)	10.5 GPM (40 LPM)	9.2 ft (2.8 m)	17.4 ft (5.3 m)
F 314 PP-32/25 F 314 S-28/25	11.6 GPM (44 LPM)	14.8 GPM (56 LPM)	15.4 ft (4.7 m)	27.9 ft (8.5 m)

Performance charts*

JUNIORFLUX

F 310 PP-25/19

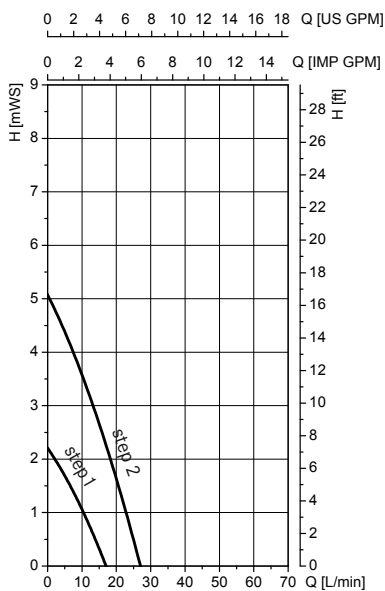

F 310 PP-32/25

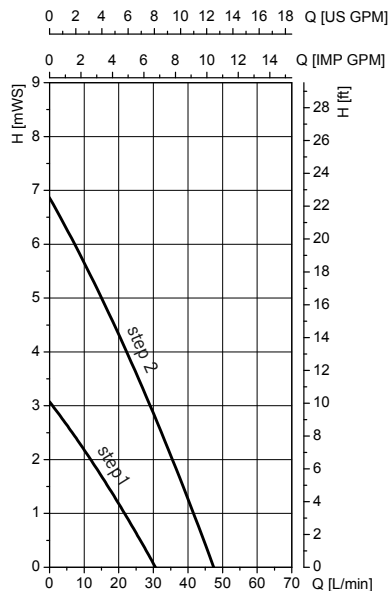

F 314 PP-25/19

F 314 PVDF-25/19

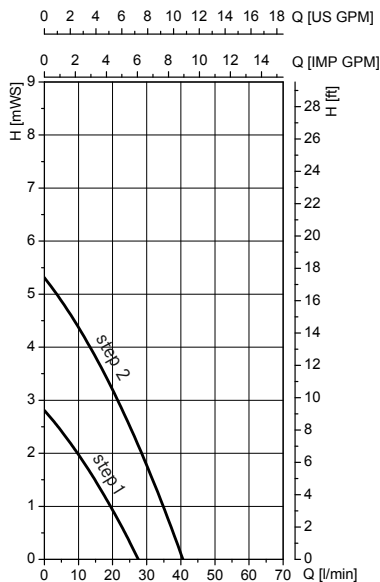

F 314 PP-32/25

F 314 S-28/25

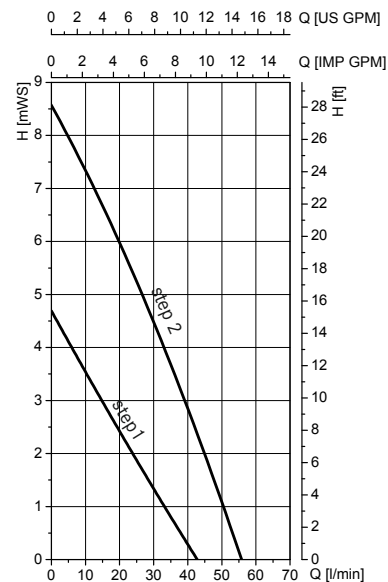

* Determined with water at 68°F (20°C), measured values ± 10 % maximum flow rate with open discharge outlet

** Measured with water at 68°F (20°C)

Dimensions

JUNIORFLUX

Dimensions [mm]

JUNIORFLUX F 310 PP

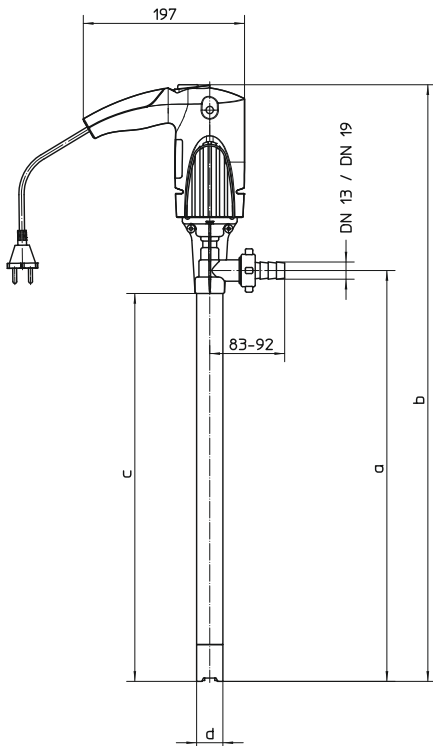

JUNIORFLUX F 314 PP/PVDF

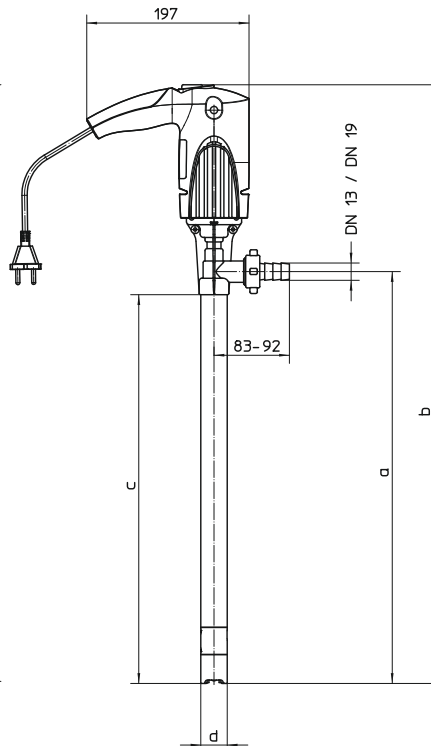

JUNIORFLUX F 314 S

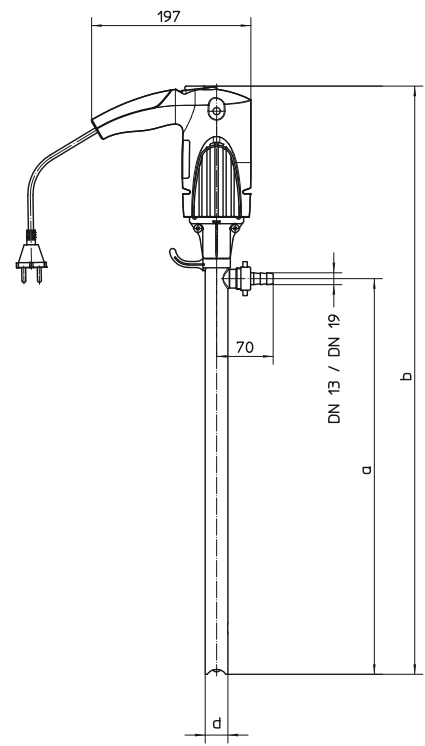

Immersion length	a	b	c	d	
39" (1000 mm)	1002	1229	974	Ø 25	Ø 32
27" (700 mm)	702	929	674		
20" (500 mm)	502	729	474		

Dimensions in mm

Immersion length	a	b	c	d	
39" (1000 mm)	1000	1227	972	Ø 25	Ø 32*
27" (700 mm)	700	927	672		
20" (500 mm)	500	727	472		

Dimensions in mm

* Version Ø 32 mm available in PP

Immersion length	a	b	c	d
39" (1000 mm)	989	1192	-	Ø 28
27" (700 mm)	689	892	-	
20" (500 mm)	489	692	-	

Dimensions in mm

Pump kit	F 310 PP-32/25	F 314 PP-25/19	F 314 PP-32/25	F 314 PP/S-32/25 AdBlue® version
Motor	FEM 3070, 230 V, 50-60 Hz, 230 W			
Cable length	16 ft (5 m)			
Type o plug according to norm:	Europe: CEE 7/XVII			
Outer tube material	polypropylene (PP)			
Seal type	with mechanical seal	sealless		
Shaft material	Hastelloy C			Stainless steel
Immersion length [mm]	39" (1000 mm)	27"/39" (700/1000 mm)	39" (1000 mm)	39" (1000 mm)
Outer Ø [mm]	32	25	32	32
Hose connector	3/4" (DN19)	1/2" (DN13)	3/4" (DN19)	3/4" (DN19)
Hose material	PVC			
Hose length [m]	4.9 ft (1.5 m)			6.5 ft (2 m)
Hose Ø	3/4" (DN19)	1/2" (DN13)	3/4" (DN19)	3/4" (DN19)
Material hand nozzle/seal	PP/FKM			
Connection hand nozzle	3/4" (DN19)	1/2" (DN13)	3/4" (DN19)	3/4" (DN19)
Hand nozzle outlet Ø [mm]	22			19
Weight [kg]	5.3 lbs (2.4 kg)			



JUNIORFLUX pump kit F 314 PP-25/19



JUNIORFLUX pump kit AdBlue®

Part numbers

JUNIORFLUX pump with fixed commutator motor FEM 3070

Pump		Motor					
Pump type	Immersion length (in/mm)	240 V, 50 Hz	230 V, 50-60 Hz	230 V, 50-60 Hz (Swiss version)	120 V, 60 Hz	110 V, 50-60 Hz	100 V, 50-60 Hz
F 310 PP-25/19	12"/300	310 41 403	310 41 003	on request	310 41 103	310 41 203	310 41 303
	20"/500	310 41 405	310 41 005	310 41 505	310 41 105	310 41 205	310 41 305
	27"/700	310 41 407	310 41 007	310 41 507	310 41 107	310 41 207	310 41 307
	39"/1000	310 41 410	310 41 010	310 41 510	310 41 110	310 41 210	310 41 310
F 310 PP-32/25	20"/500	310 42 405	310 42 005	on request	310 42 105	310 42 205	on request
	27"/700	310 42 407	310 42 007	310 42 507	310 42 107	310 42 207	
	39"/1000	310 42 410	310 42 010	310 42 510	310 42 110	310 42 210	
F 314 PP-25/19	20"/500	314 41 405	314 41 005	314 41 505	314 41 105	314 41 205	314 41 305
	27"/700	314 41 407	314 41 007	314 41 507	314 41 107	314 41 207	314 41 307
	39"/1000	314 41 410	314 41 010	314 41 510	314 41 110	314 41 210	314 41 310
F 314 PP-32/25	20"/500	314 42 405	314 42 005	314 42 505	314 42 105	314 42 205	on request
	27"/700	314 42 407	314 42 007	314 42 507	314 42 107	314 42 207	
	39"/1000	314 42 410	314 42 010	314 42 510	314 42 110	314 42 210	
F 314 PVDF-25/19	20"/500	314 61 405	314 61 005	314 61 505	on request	314 61 205	314 61 305
	27"/700	314 61 407	314 61 007	314 61 507		314 61 207	314 61 307
	39"/1000	314 61 410	314 61 010	314 61 510		314 61 210	314 61 310
F 314 S-28/25	20"/500	314 21 405	314 21 005	on request	314 21 105	314 21 205	314 21 305
	27"/700	314 21 407	314 21 007	314 21 507	314 21 107	314 21 207	314 21 307
	39"/1000	314 21 310	314 21 010	314 21 510	314 21 110	314 21 210	314 21 310

JUNIORFLUX pump kits with motor 230 V, 50-60 Hz, 230 W

Pump type	Immersion length	Outer Ø	Part no.
F 310	39" (1000 mm)	32 mm	310 43 010
F 314	27" (700 mm)	25 mm	314 43 007
F 314	39" (1000 mm)	25 mm	314 43 010
F 314	39" (1000 mm)	32 mm	314 44 010
F 314 AdBlue®	39" (1000 mm)	32 mm	314 44 ZV2

Other accessories:

We offer the appropriate accessories for the JUNIORFLUX, such as: hand nozzles, hoses, compression glands or liquid meters. See our brochure for accessories and the price list for the precise specifications.

FLUX PUMPS CORPORATION

300 Townpark Drive, Suite 110
 Kennesaw, GA 30144, USA
 Phone 800-367-3589
 info@fluxpumpsusa.com
 www.fluxpumpsusa.com