

FLUX three-phase gearmotor F 414 in detail

The robust three-phase gearmotor F 414 is especially designed for extreme operating conditions and extended operating periods.



F 414

Three-phase gearmotor, protection class I, jet-proof to IP 55, available with motor protection switch or with cable terminal box, without power supply cable.

type	capacity	voltage	frequency	range of setting motor protection switch	weight	part no. version	
						with motor protection switch, mounted on the motor	without motor protection switch, with cable terminal box
F 414	0,55 kW	230/400 V	50 Hz	0,9 – 1,6 A	19/18 lbs	414 01 112	414 01 110
F 414	0,75 kW	230/400 V	50 Hz	1,5 – 2,5 A	25/23 lbs	414 01 137	414 01 136
F 414	1,1 kW	230/400 V	50 Hz	2,4 – 3,5 A	28/26 lbs	414 01 139	414 01 138

accessories:		part no.
carrying handle	allowing an easy immersion and removal of the pump in combination with the three-phase Gearmotor F 414	001 10 582
power supply cable	16" long, complete with Cekon plug, 5-pole	934 08 020
power supply cable	16" long, without plug	934 08 025
power supply cable	yard ware	934 08 901
cekon plug	5-pole	937 01 014

motor F 414 in combination with drum pump in stainless steel

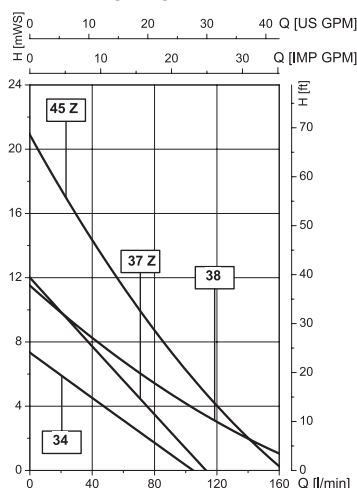

motor F 414 in combination with drum pump in aluminium and hastelloy C

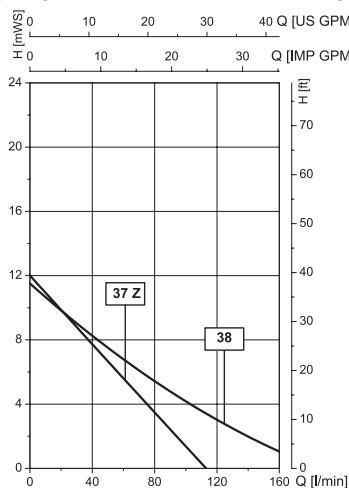

motor F 414 in combination with drum pump in PP and PVDF

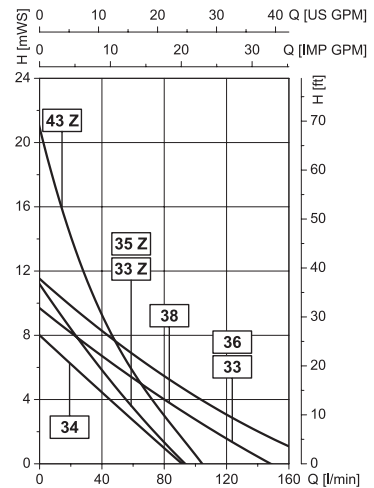

Haltebügel nicht im Lieferumfang des Motors enthalten!
 Carrying handle not included in the motor!
 Etrier de manipulation non-compris dans le moteur!

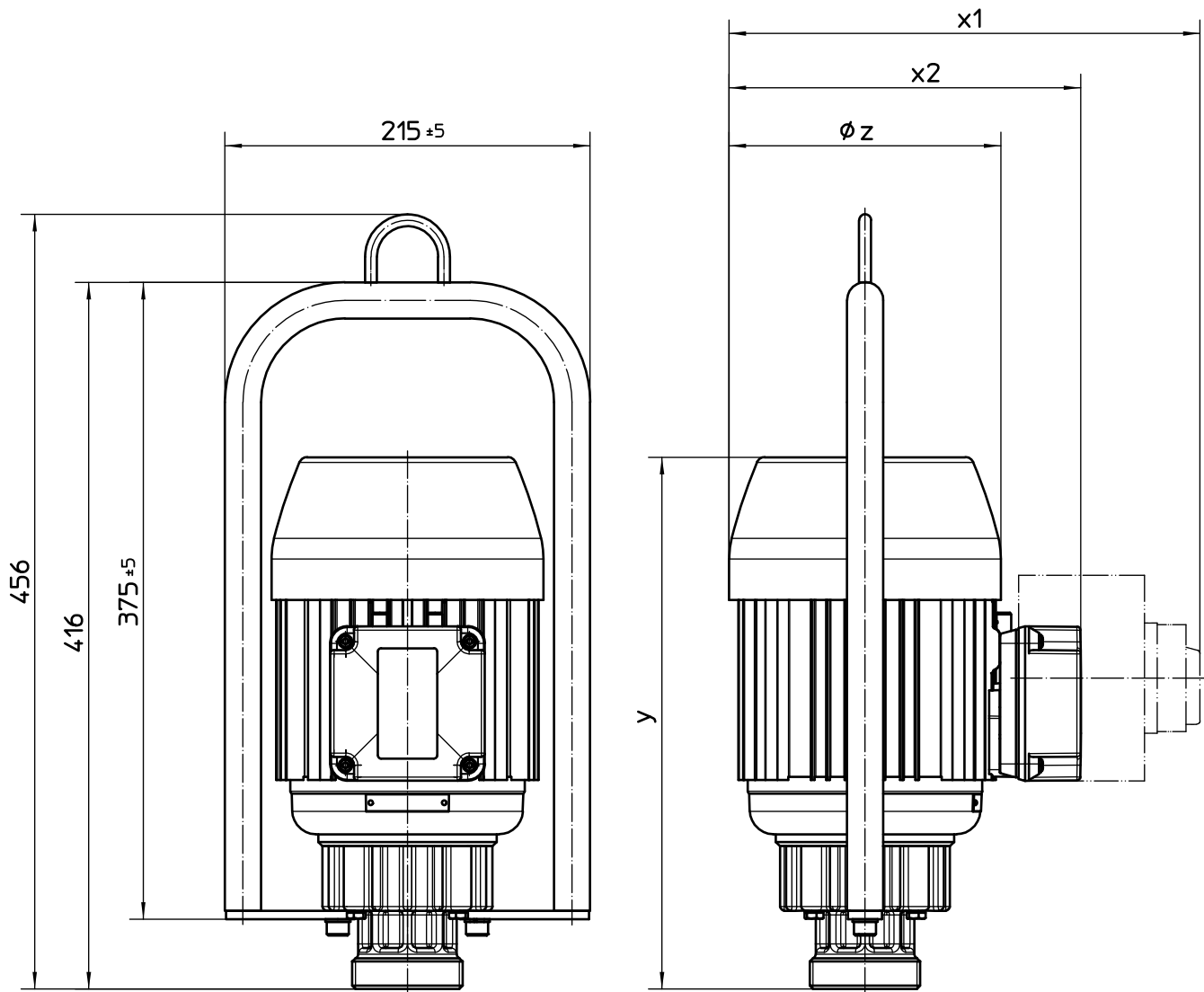

≥ 0,75 kW	277	313	160	208	313	160
≥ 0,55 kW	257	285	143	200	285	143
Leistung Capacity Puissance	x1	y	øz	x2	y	øz
	mit Motorschutzschalter with motor protection switch avec commutateur-disjoncteur			ohne Motorschutzschalter without motor protection switch sans commutateur-disjoncteur		